

Introduction

The output voltage of power supplies and DC to DC converters is regulated by dividing down the output, comparing it with a stable reference, amplifying the error, and then using this error signal to control the input to output power transfer. Many applications use an expensive and unreliable mechanical potentiometer in the divider to precisely set the output voltage, as shown in Figure 1.

For fixed output supplies, manually adjusting the mechanical pot is a costly and time consuming operation that is prone to error. Physical access to the pot must be provided, which often requires less than optimal PCB layout and additional access holes in the chassis of enclosed units. Though initially set during production, the mechanical pot is subject to shock and vibration, incurring wiper position changes. Humidity and moisture can result in resistive changes and the prying hands of service technicians or end users can also affect accuracy. For variable output supplies, mechanical pots prevent the option of automated or remote adjustment.

To overcome these problems, a potentiometer would have to be electronically programmable in order to eliminate costly and potentially inaccurate manual settings, nonvolatile so as to power-up at the proper setting, and re-programmable for testing in the factory or for adjustments in the field.

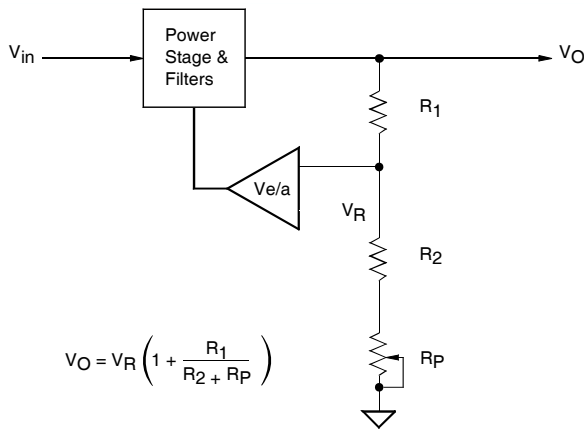

$$V_O = V_R \left(1 + \frac{R_1}{R_2 + R_P} \right)$$

FIGURE 1.

Implementing Designs with XDCPs

An example of a part that meets all of these requirements is the X9CMME from Intersil, shown in Figure 2. This electrically erasable, programmable nonvolatile potentiometer greatly simplifies manufacturing and test, and with a wiper position retention in excess of 100 years, can significantly increase field reliability.

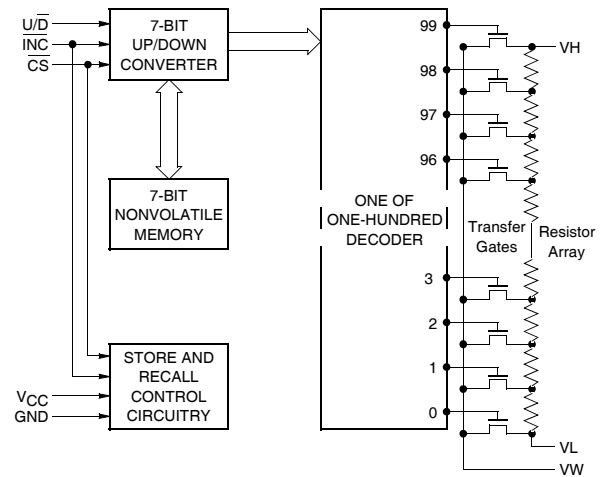

FIGURE 2.

Available in 8-pin DIP or SOIC packages, the 100 wiper position X9CMME is easily implemented into a circuit. Terminal connections are made in the same way as a mechanical pot. The three control lines of the part can be brought out through a connector to automate programming and to test equipment, as shown in Figure 3.

\overline{INC} , $\overline{U/D}$, and \overline{CS} pins control the setting of the wiper. Pulling \overline{CS} LOW enables the part. Each HIGH to LOW transition on the \overline{INC} line increases or decreases (depending on the state of $\overline{U/D}$) the resistance of the pot. After reaching the desired output voltage, the final wiper setting can be stored in nonvolatile memory by bringing \overline{CS} HIGH while \overline{INC} is HIGH. This ensures that the X9CMME powers-up at the last setting. It may appear that this is the only operating sequence for power supply applications, but there is at least one important scenario where wiper position storage is not required.

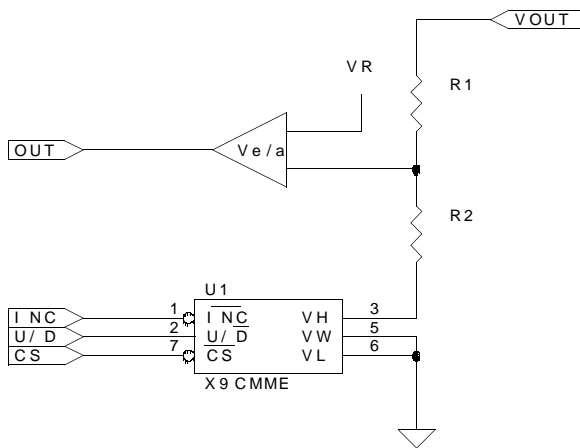

FIGURE 3.

Overvoltage Testing

Overvoltage (OV) testing has always presented a challenge to the manufacturing engineer. If a mechanical potentiometer is available, it must be adjusted manually to test the OV protection circuitry and then be readjusted to reset the output voltage. If there is no potentiometer in the system, or even if there is one that is not easily accessible, an external power supply must be connected to the unit under test (UUT). The voltage on the external supply is then raised while monitoring the UUT, to determine the point at which it shuts down. This often requires observation of waveforms internal to the UUT that are also difficult to access, compounded by the fact that the UUT control circuitry may obscure the response of the OV protection circuitry. This cumbersome procedure can be eliminated through the use of XDCPs.

If the output voltage in Figure 3 is 5V, with a 2.5V reference, and R1 is 10kΩ and R2 is 4.99kΩ, a good choice of XDCP for voltage regulation and overvoltage testing would be the X9C103 (10kΩ version of the X9CMME). Having adjusted the output voltage to meet spec. at some nominal line and load, and after storing this setting in nonvolatile memory by deselecting the part with INC HIGH, the testing of the power supply can begin. When the OV portion of the test is reached, the output voltage is increased by toggling the INC pin of the XDCP while holding U/D LOW. Upon reaching the OV trip point and the supply shutting-down, the final value of the output voltage can be automatically recorded and compared to a maximum allowable value. The automatic test equipment (ATE) could then generate a pass/fail response. Provided CS does not transition from HIGH to LOW with INC HIGH, the OV trip point wiper position will not be stored and the XDCP will return to the previously calibrated regulation voltage upon power-up. This approach provides an accurate, automated means of overvoltage testing.

The X9CMME provides 100 tap positions for terminal voltages of ±5V and is available in 1kΩ, 10kΩ, 50kΩ, and 100kΩ versions. The X9312 gives an extended 0 to 15V terminal voltage capability and the X9313 provides an inexpensive 32 tap alternative. All single XDCPs share the same pinout and are available in DIP and SOIC packages.

Quad XDCP

For multiple output power supplies or in applications where resolution greater than 100 wiper positions is required, Intersil offers the X9241 quad XDCP, shown in Figure 4. Designed to interface directly with a microcontroller, the X9241 can be directly programmed with a wiper position or incremented/decremented tap-by-tap like the X9CMME.

The X9241 contains four 64 wiper position pots in a single 20 pin package. Each pot has a wiper counter register (WCR) that controls the wiper position and four nonvolatile registers that store wiper settings. The part provides four pins for device addressing, allowing as many as 16 devices to share the same bus, using an instruction oriented protocol. Registers and wiper positions can be read and written by the ATE using a two-wire bidirectional serial interface.

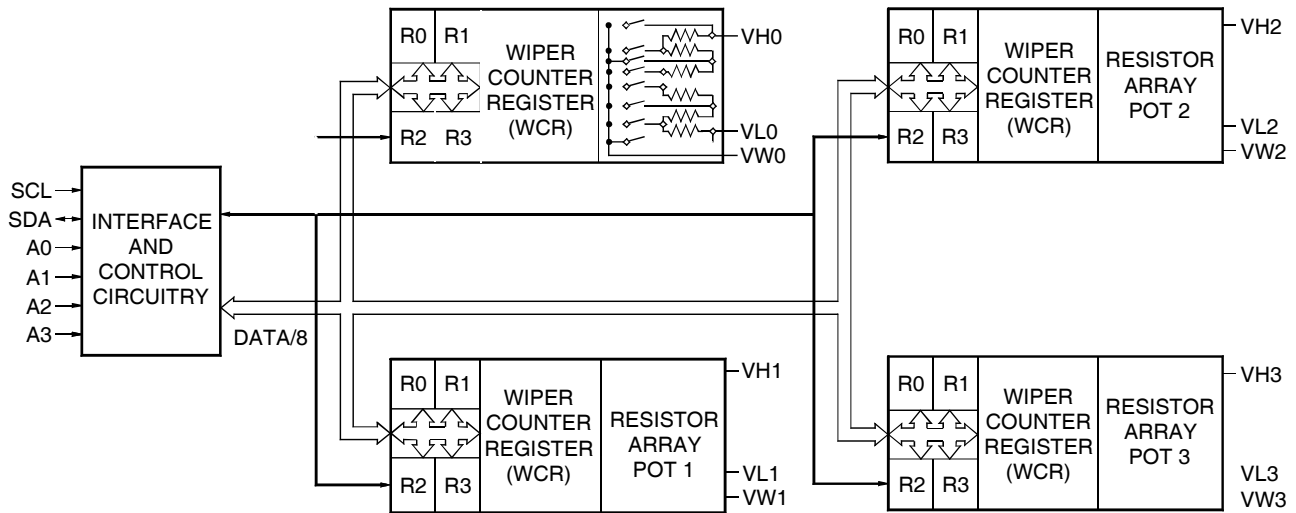

FIGURE 4.

Internal support is available for cascading pots together in series or parallel to increase resolution and provide larger or smaller potentiometer values. These cascading configurations can be implemented in any number of ways using two or more pots. For example, using the X9241M (2kΩ, 10kΩ, 10kΩ, 50kΩ combo version), two pots can be used to give a fine and course adjustment for setting the regulated output voltage and testing the overvoltage circuitry. This configuration is shown in Figure 5. Pot 3 can be used to provide course adjustment with 800W (50kΩ/63) steps and pot 0 to provide fine adjustment with 32W (2kΩ/63) steps. The wiper position is changed using the increment/decrement or write WCR commands. Wiper settings are stored in nonvolatile memory by directly writing to data registers or transferring data from WCRs to data registers. Each pot's WCR is loaded with contents of data register 0 upon power-up.

The X9241 is a ±5V terminal device available in 2kΩ, 10kΩ, 50kΩ, and combination versions, with either DIP or SOIC package options. This digitally controlled IC greatly simplifies and automates manufacturing and test. Like the X9CMME, nonvolatile storage retention of the X9241 is at least 100 years, providing a significant increase in field reliability.

Conclusion

Nonvolatile XDCPs provide significant advantages over mechanical potentiometers for power supplies in both manufacturing and in the field. Automated assembly and test provide labor savings, while increasing repeatability and eliminating human error. Immune to shock and vibration, and with superior resistance to environmental stress, XDCPs increase long term reliability. In the never ending struggle to cut costs and increase quality, Intersil XDCPs are a major enhancement in the design of power supplies and DC to DC converters.

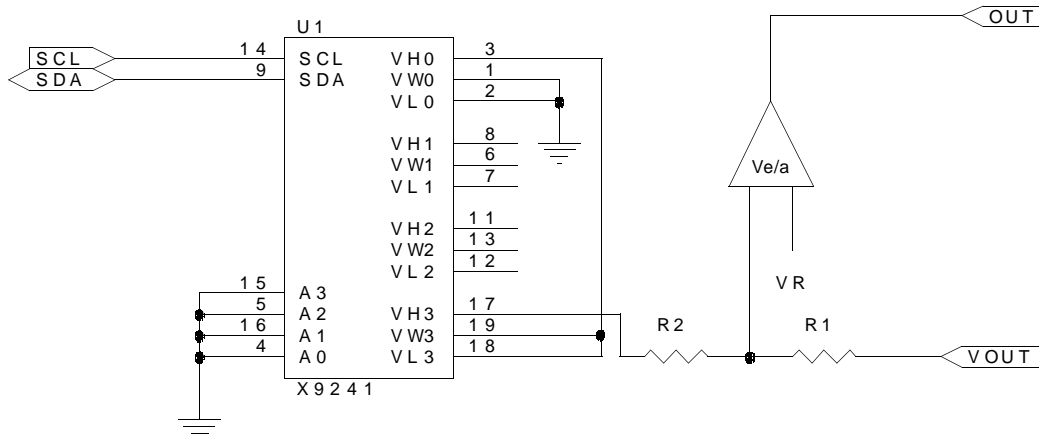

FIGURE 5.

Intersil Corporation reserves the right to make changes in circuit design, software and/or specifications at any time without notice. Accordingly, the reader is cautioned to verify that the Application Note or Technical Brief is current before proceeding.

For information regarding Intersil Corporation and its products, see www.intersil.com